

Excel

!CLICK-&-GO™

Innovation in wheelchair power support systems



Excel Click & Go powerpack

Technically advanced, easy to attach under your wheelchair and easily operable.

The Excel Click & Go is equipped with two-wheel drive and a microprocessor-driven programmable electronics. The unit fits under almost any foldable wheelchair through the use of a universal mounting kit.

The progressive qualities ensure that there is always enough grip. The motor is equipped with an automatic electro-magnetic brake, to ensure the users safety.

The Click & Go comes with as standard:

- Battery charger
- Battery pack including carrying case
- Manual operation cabinet
- Mounting instructions
- Adaptation plates
- Extension for push handles
- Assembly manual on CD ROM

The wheelchair that you wish to mount a Click & Go powerpack to must meet the following conditions:

- The space between the sideframes must be at least 34 cm
- The distance between the centre of the rear wheels and rear of the crossbrace must be at least 25 cm
- The wheelchair must have a circular horizontal tube of at least 19 mm to 25 mm diameter
- The clearance at the rear of the wheelchair must be at least 40 cm
- The wheelchair should be equipped with anti-tip wheels for safety



Easy to use! Mountable in just a few moments.



'Smart mobility solutions'

Overall width: mounts onto wheelchairs with seat width 40-50 cm
 Overall length: 38 cm
 Overall height: 46 cm
 Drive Wheels: 200 x 50 mm

Weight (complete): 18 kg
 Weight (without batteries): 10 kg



Product complies with crash test EN12184

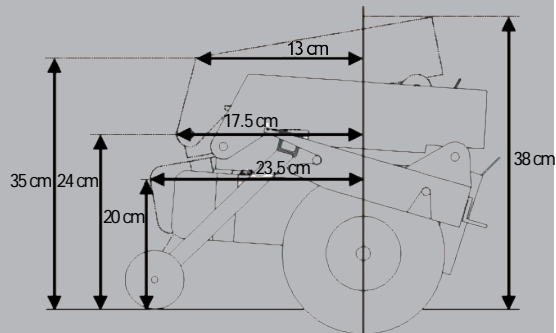

Van Os Medical UK Ltd
 42-44 Ousegate, Selby
 YO8 4NH

Tel.: +44 (0) 1757 701177
 Fax: +44 (0) 1757 706011

sales@vanosmedical.com

We have a continuous product improvement policy and consequently reserve the right to amend design and specifications without prior notice all errors and omissions excepted.
 All rights reserved. Copyright 2009 Van Os Medical B.V.